

# SERJEANT-AT-ARMS GOWN

## You will need:

- 1 2 m of black fabric
- 2 black cotton
- 3 sewing needle
- 4 sewing machine
- 5 scissors
- 6 tape measure
- 7 sewing chalk and/or sewing pins
- 8 a flat, clean surface to work on

## Key:

-  --- cut here
- ..... fold here
-  wrong side of fabric
-  right side of fabric
-  centre point
- - - stitching



The Serjeant-at-Arms gown  
modelled by a student



## 1

### Cutting out the fabric pieces

- Lay 2 m of black fabric as a single layer on a flat, clean surface.
- Measure and cut the gown front, back, two sleeves and two tails as indicated on the diagram below.



You should now have six pattern pieces that look like this:



**2**

## Shaping the back panel

a) Fold back piece in half to find centre back. Make sure edges match.

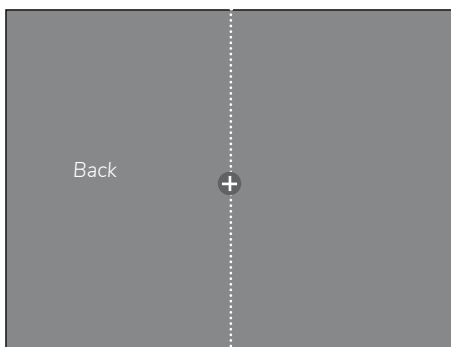

b) Use sewing chalk or pins to mark back neck shape. Cut neck shape out along folded edge.

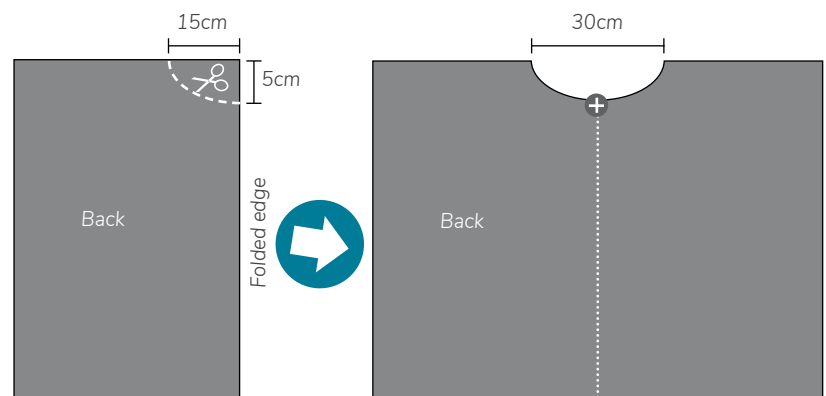

Your back piece should look like this.

3

### Shaping the front panel

- a) Fold front piece in half to find centre front. Make sure edges match.

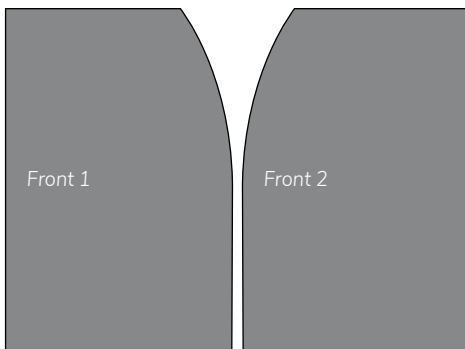
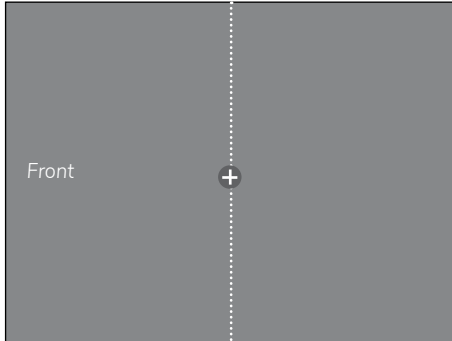

- b) Use sewing chalk or pins to mark front neck shape. Cut neck shape out along folded edge.

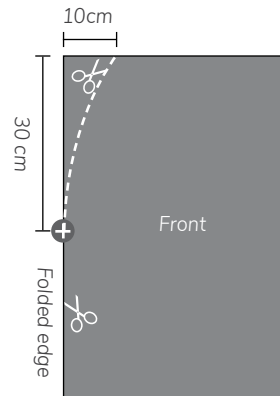

You should now have two separate front panels.

4

### Pleating the back panels

- a) Find the centre back and mark with chalk or pin.

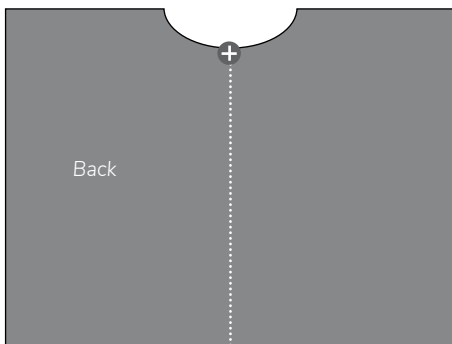

- b) Draw together and pin a 1 cm pleat with the fold of the pleat at centre back.

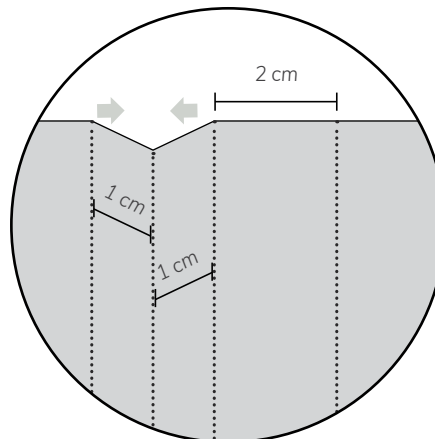

- c) Pin another 7 pleats on either side of the central pleat to create a total of 15 evenly spaced shallow pleats across the back. There will be about a 2 cm gap between each pleat.

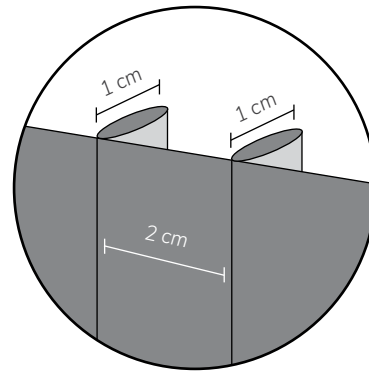
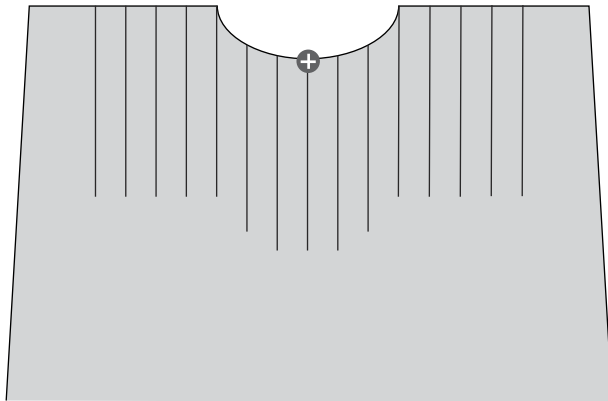

Once sewn, your pleats should look like this

**5**

## Pleating the front panels

- a) As in Step 4, pin seven 1 cm evenly spaced pleats on each of the two front panels. There will be about a 2 cm gap between each pleat. Make sure that some fabric remains unpleated at either end of the upper edge of both front panels for joining to sleeves.

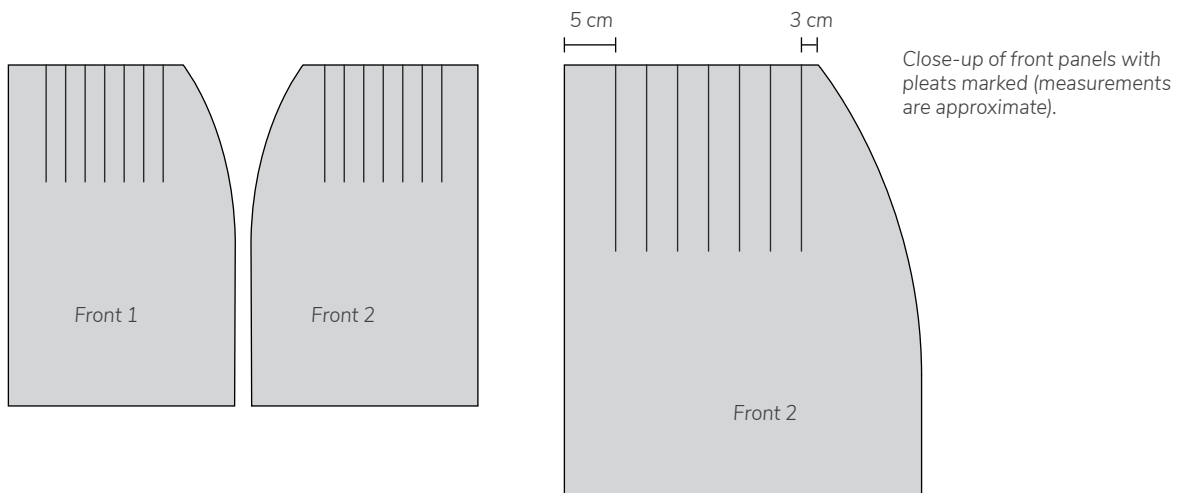

- b) Before sewing the pleats check that the front and back fit neatly together at shoulders (see Step 6).
- c) Sew pleats.

Your front panels should now look like this.

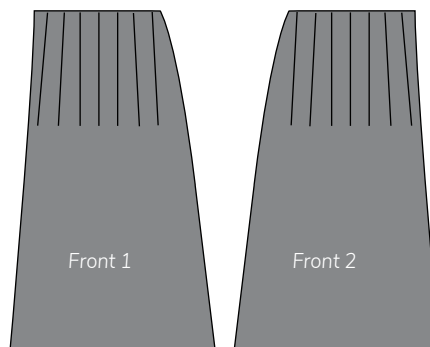

6

## Sewing the front and back panels together

a) Pin front and back panels right sides together at the shoulders.

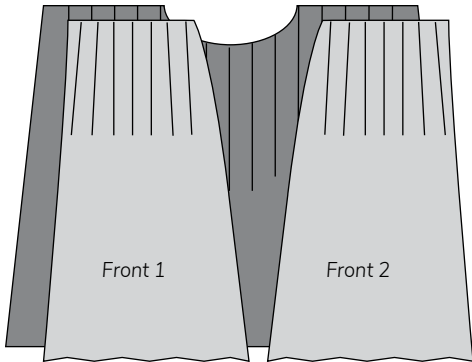

b) Sew back and two front panels together at the shoulders.

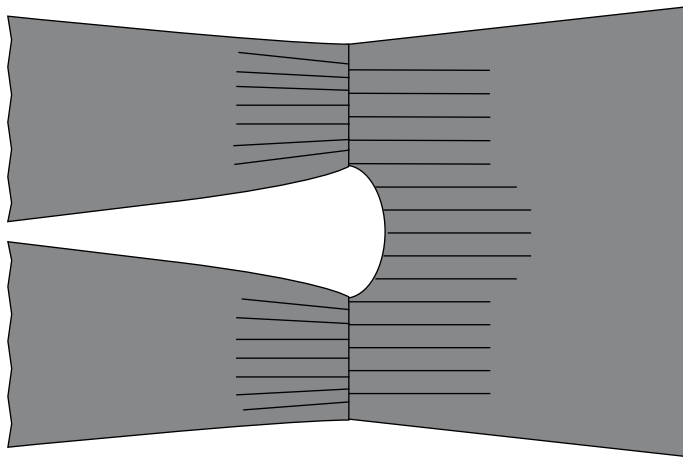
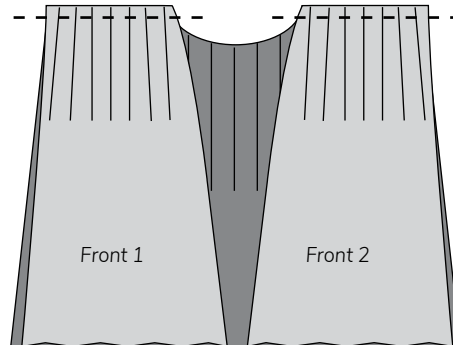

c) Your front and back should look like this when laid flat.

7

## Hemming the front and neck

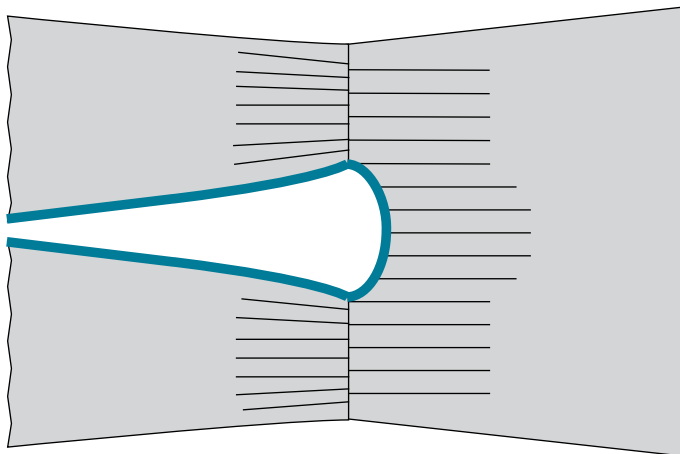

a) Pin and sew a shallow hem on both front panels, and the neck.

## 8

## Attaching the sleeves

- a) Fold sleeve 1 edges together and mark the centre point. Repeat for sleeve 2.

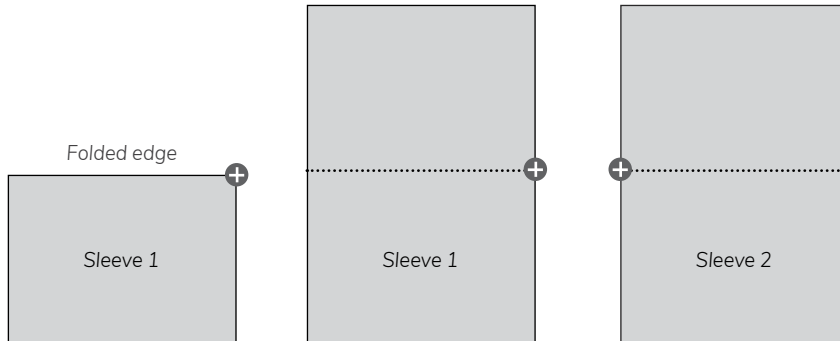

- b) Pin sleeve 1 to front and back at shoulders, right sides together. Repeat for sleeve 2.  
c) Sew seam to attach each sleeve.

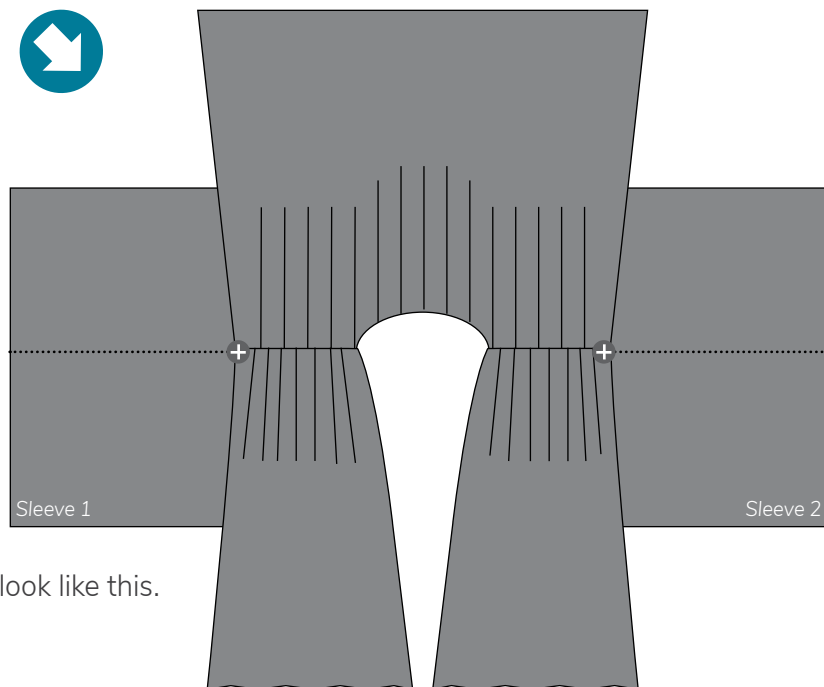

Your jacket should look like this.

9

## Sewing the jacket together

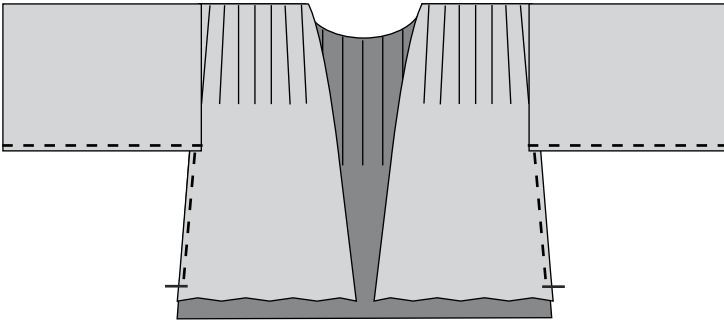

Your jacket should look like this.

- a) Pin bottom edge of sleeves, right sides of fabric together, to create two sleeve seams.
- b) Pin back and front right sides of fabric together to create two side seams, stopping just short of bottom edge.
- c) Sew the sleeves and sides together.

10

## Hemming the jacket

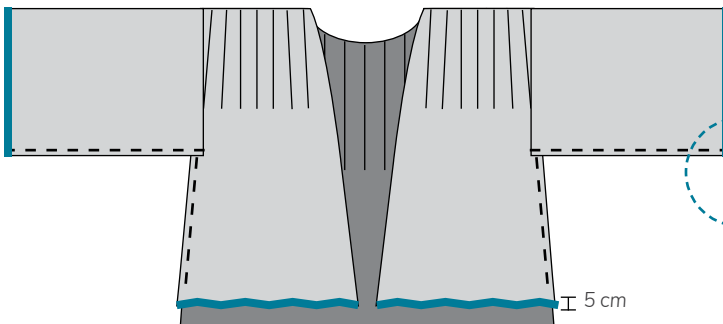

- a) Pin a hem along both front panels only. Adjust hem to required length and sew on the wrong side of fabric.
- b) Pin a shallow hem on the bottom edge of each sleeve. Sew hem on the wrong side of the fabric.

# 11

## Shaping and hemming the coat tails

- a) Fold tail pieces in half longways to find and mark the centre point. Make sure edges are matched.
- b) Use sewing chalk or pins to mark scallops at the bottom of each tail.
- c) Cut tails to shape.

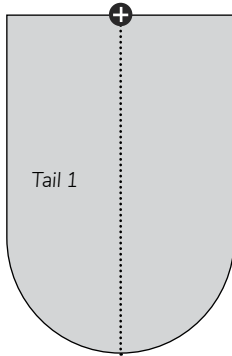
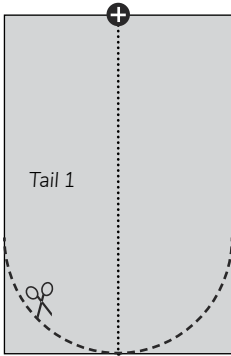
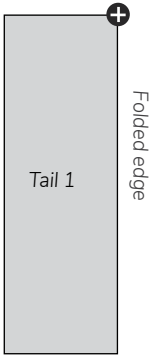

- d) Pin a shallow hem on both tails. Sew the hem on the wrong side of fabric.

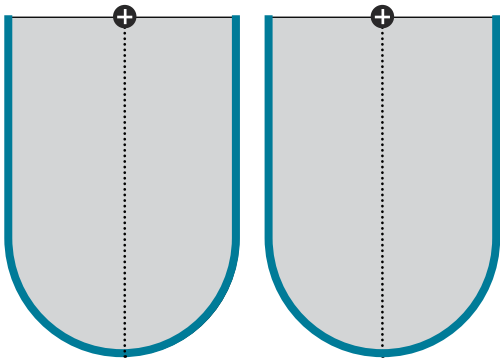

# 12

## Attaching tails to the back of the jacket

- a) Pin tail 1 and tail 2 to the bottom of edge of the jacket back with right sides together. Sew seam to attach each tail to the back of the jacket.

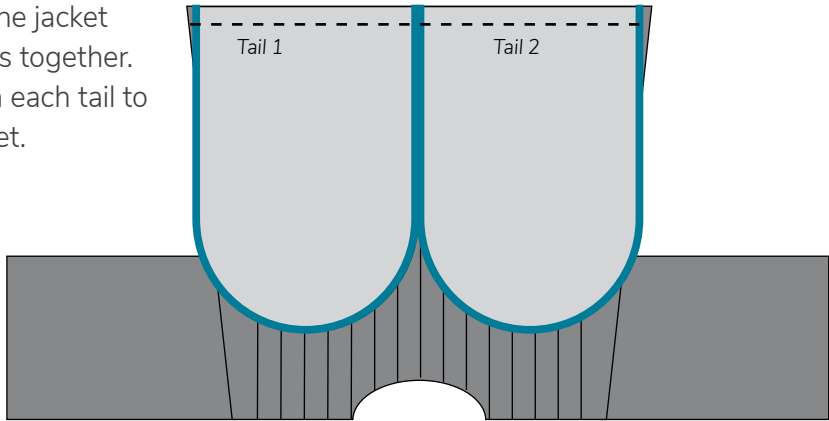



- b) Turn gown right side out and dress your Serjeant-at-Arms for a parliamentary role-play experience!

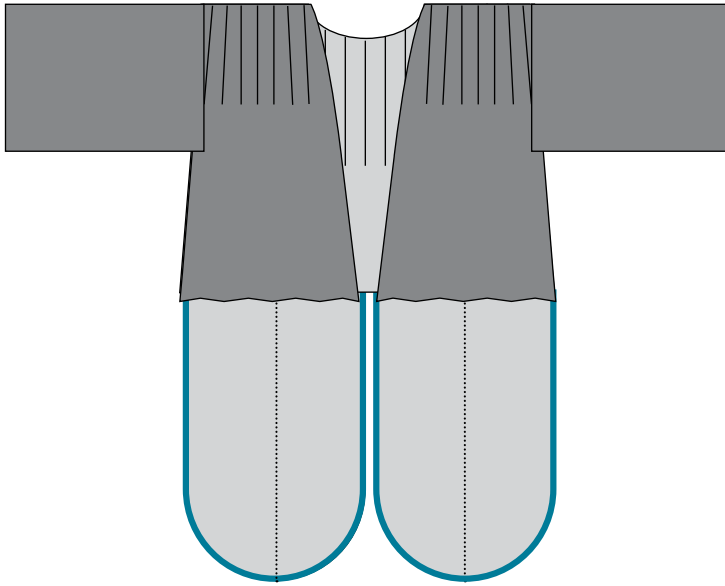

Your jacket should now look like this.



Students enacting the roles of Serjeant-at-Arms and Speaker during a role-play.